

## The DRAGON series High Power LED Light Sources

### Features

- Flexible Layout: Ring, Square, User Specified
- 395, 405, 455nm, 475nm, 505nm, 530nm, 590nm, 617nm, 630nm, white 5500 K, white 3300 K (others available, inquire)
- Aperture Option for Cameras, Spectrometers
- Cross-cooling adapted for camera inserted
- Color Mixing – RGB or other
- Fast analog control
- Fast pulsed (digital) control (some models)
- Narrow bandwidth or broadband
- Wide field, individually adjustable optics
- Continuous, waveforms, or pulses to <200 ns
- Up to 0.35W/LED CW, x5 intensity short pulse
- Electronics and LED/Optics modules allow scaling to very large configurations

### Description

The HPLS-692 series of high power LED light sources are designed as flexible system for wide range of applications. Individual illuminators (LED and optics) can be laid out in a pre-specified pattern such as a ring, square, or any other pattern to form a cluster that fits in the 6" X 9" Panel. LEDs are individually user-replaceable. Each illuminator has individual set of optics.

Detector such as high-speed camera or spectrograph can be inserted though up to 3" opening in the center of the enclosure for shadow-free collinear detection.



### Applications

- Fluorescence excitation
- High-speed imaging
- Pressure Sensitive Paint
- Schlieren Imaging
- Synchronous detection
- Machine vision
- Biomedical optics

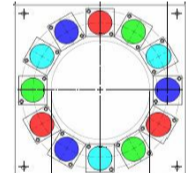
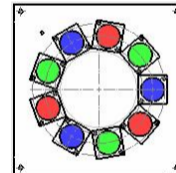
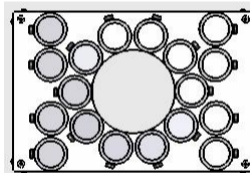

### HPLS-692 series structure

- Enclosure containing driver
  - Analog & Digital (versatile)
  - High speed option
  - Analog (max CW power)
- LED Cluster: any pattern
  - Ring
  - Filled
  - Rectangular array
- Set of LEDs
  - Color Selection
  - Individual or Multiple Colors
  - Easy to change
- Optics
  - Collimation
  - Beam Deflection

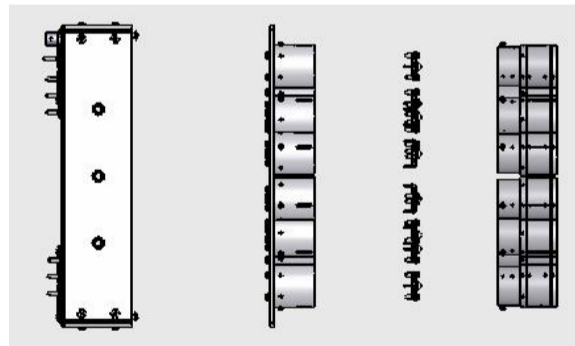

Driver Enclosure    Cluster    LEDs    Optics

# HPLS-692AD3500-DI Driver



## Description

HPLS Enclosure with built-in 3- or 6-channel AD3500 driver. Each channel accepts 3 or 4 LEDs. Equipped with dual input (-DI index), both Analog and Digital channel are individually accessible. The Analog channel has linear control and continuously variable output, with 1% input offset to ensure shutdown when signal is not applied. Digital channel has 2-level ON-OFF control (active HI). The Analog channel is designed to convert the input voltage into output current as precisely as possible and as fast as reasonable but not to hurt the precision; while the Digital mode is optimized for switching the current to MAX level and back to 0 as fast as possible. The current in Digital mode varies slightly for different LED heads; in the Analog channel the current is regulated to be the same. Output current in the sum of outputs of both channels.

Test mode allows quick testing LEDs, alignment, and targeting.

Enclosure is equipped with active cooling optimized for presence of the camera or objective in the thru-hole opening in the center of the enclosure.

## Specifications

- Two channels: Analog and Digital
- Base dimensions: 6x9x2" (152x228x50mm)
- Weight: about 1 kg (without cluster and optics)
- Power Requirement: 24V, 3A
- Power Connector: 5.5/2.5 mm Power Jack, center positive, barrel common ground
- Control Signal Connectors: 2x BNC

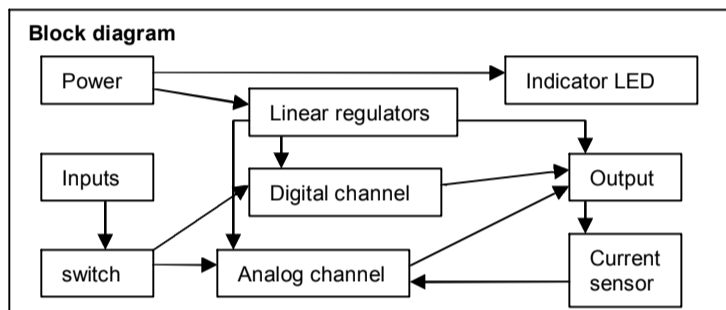

## Absolute Maximum Ratings

- Power Input: -1 to 40V; -3A to 3A; fuse protected (2A)
- Signal Input, Digital Mode: -2.5V to 7V; 50mA max, 50 Ohm input impedance
- Input, Analog Mode: -10V to 20V

### Control panel:

- Main switch: On, Off, Test
- On (up): external control
  - Center: OFF
  - Test (down): Forced on
- BNC connectors:
- Central pin: input signal
  - Barrel: common ground
- LED: input power/fault indicator
- Power: 5.5/2.5mm, Central positive
- Subset Switches (optional):
- up-ON,
  - down-OFF

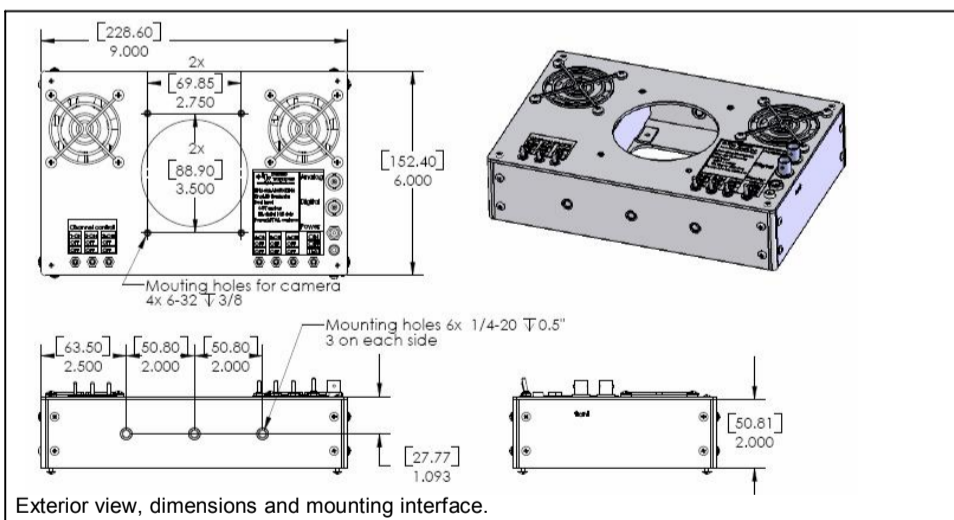

## Options and Accessories

- LED patterns (ring, square, linear, etc)
- Apertures
- Interchangeable Colors
- Multiple Colors
- UV and IR options
- Beam Deflection to 16 degrees
- High Speed Drivers

## Waveforms and specifications

### Digital mode specifications:

- Output current: 3.5A +/- 0.3A (LED head dependent)
- Rise Time: 120ns (to 1/2 level); 300ns (to 90%)
- Rise front propagation delay: 50ns typ
- Fall Time: 80ns (to 1/2 level); 120ns (to 90%)
- Fall front propagation delay: 50ns
- Pulse front/fall jitter: < 10ns, <5ns typ
- Nominal Signal Level: 3.3-5V; TTL/CMOS
- Logical "0" (light OFF): <0.8V
- Logical "1" (light ON): >2.4V
- Smart Time Limiting Circuitry for LED Protection Limits the Cumulative Energy Delivered to LED
- Single Control Pulse length range: 50ns-1ms
- Maximum Duty Cycle of Continuous Waveform: 10%
- Average Ratio, Active Time/Relaxation Time: 1:10
- Any Repetition Rate
- Trimmer on the Board to Down Regulate the Pulsed Current and Optical Power

### Digital mode, protocol examples:

- Example 1: 1us pulse permitted every 10us
- Example 2: 1 ms max duration pulse every 10ms
- Example 3: 50% duty cycle waveform 2ms total duration, permitted every 10ms
- Example 4: 20% duty cycle waveform 5ms total duration, permitted every 10ms
- Example 5: 200ns starting pulse: optical pulse has Gaussian profile, 420ns(1/2), peak is 100% of steady level
- Example 6: 100ns starting pulse: optical pulse has Gaussian profile, 270ns(1/2), peak is 80% of steady level
- Example 7: 50ns starting pulse: optical pulse has Gaussian profile, 200ns(1/2), peak is 60% of steady level

### Analog mode specifications:

- Input/Output relationship: Linear, 1% offset
- Output current, continuously variable: 0-500mA
- Output current drift: < 800ppm/hour
- Output current accuracy: +/-3% of set value
- Output current RMS noise: <0.5%
- Input Signal Format: User Programmable (4-Dip switch on the driver board)
- Input Signal Format (Default): 0-5V
- Input Signal Formats: 0-10V; 0-20mA, 4-20mA
- Rise Time/Delay for 0-250mA transit: 400ns(50%), 1.2us(90%) / 1.8us Delay
- Fall Time/Delay for 250-0mA transition: 750ns(50%), 500ns(90%) / 20ns Delay
- Rise Time/Delay for 50-300mA transition: 350ns(50%), 800ns(90%); 20ns Delay

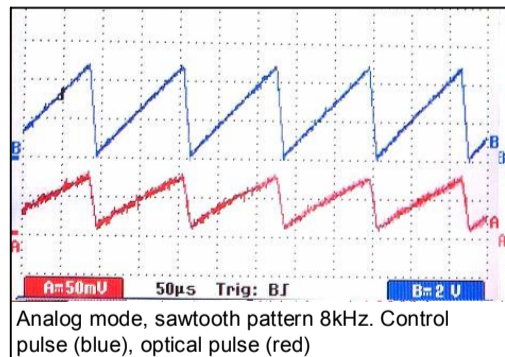
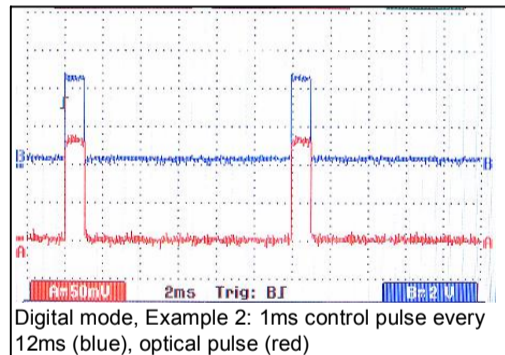
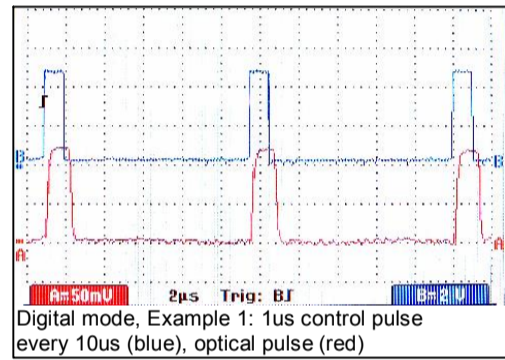
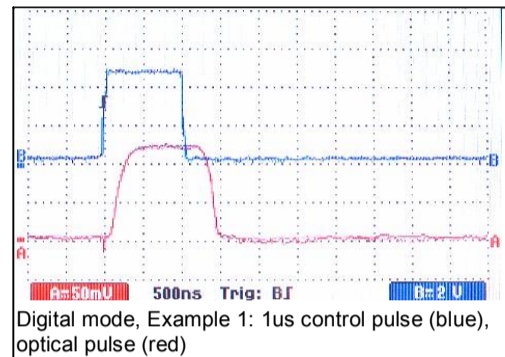

# HPLS-692-AS7-18 Cluster



## Description

HPLS-692 series cluster is equipped with 18 individual illuminators arranged in 10-ring around central thru-hole and 8 illuminators in 2 linear patterns of 4. Individual illuminators consist of LED socket, LED head, barrel, collimator, and Dual prism Assembly. LED socket allows quick change of LED heads. Barrel is designed to allow focus adjustment by sliding collimator in and out. Dual Prism assembly consist of 2 prism allowing continuously variable deflection of individual beams in the range of 0-16degrees.

## Specifications

- Central thru-hole for detector 3.125" (79mm)
- Base dimensions: 6x9" (152x228mm)
- Weight: 1.5 kG (fully equipped with optics)
- Individual collimators (18 ea):
  - Aperture: 25mm linear, 0.1NA
  - Deflection range: 0-16degrees
  - Adjustable focus

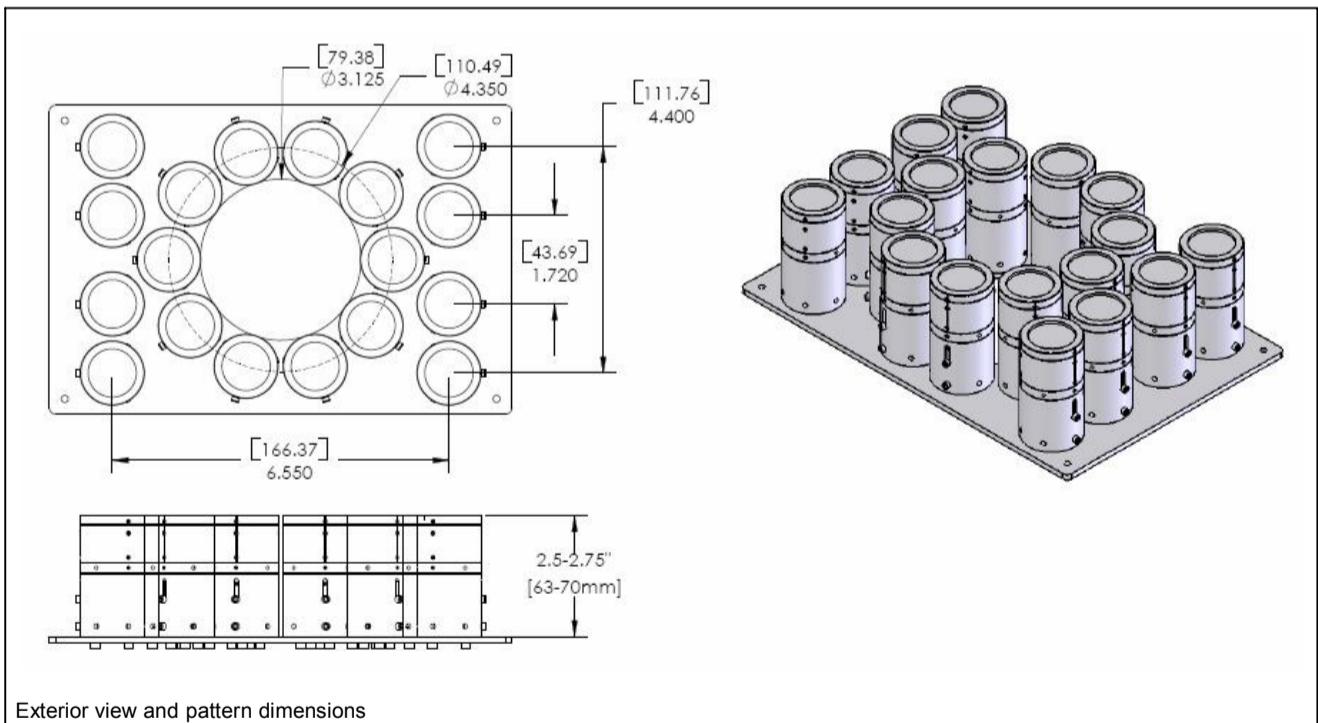
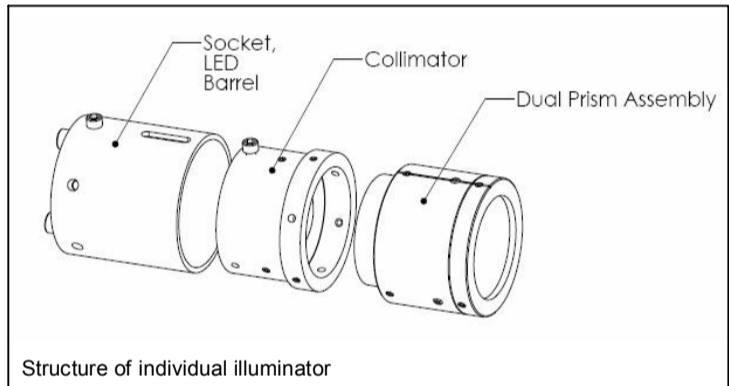

# LED Heads

## LEDH, LEDHR series



### Specifications p.1

LEDH and LEDHR are user-replaceable, LED-based light sources, attached to the HPLS-36 series base units, which provide electrical connection to the driver, means of mechanical mounting and the heat dissipation from the LED. Available in two form factors – LEDHR, bigger, with build-in reflector to collimate the light emitted from the LED, and LEDH, smaller, higher performance, un-collimated light source. Reference to the table below for typical optical power achievable by 14 different models of LED heads when plugged into various HPLS-36 models. For spectral information, form factors, and temperature coefficient of optical power, see the next page.

HPLS-36[ ] model suffix <sup>(5)</sup>	AD500		AP750		AP1000		AD3500		AD3500		AD3500					
	DD500	AD3500	AR750	AT750	AR1000	AT1000	AD3500-DI	AD3500-DI	AD3500-DI	AD3500-DI	AD3500-DI	AD3500-DI	AD3500-DI	AD3500-DI	DD7500	DD7500
Optical power range, min-max, mWt <sup>(3), (4)</sup>																
	min	max	min	max	min	max	min	max	min	max	min	max	min	max	min	max
Current, A	0.5		0.75		1		3.5		3.5		3.5		7.5		7.5	
duty cycle, % <sup>(6)</sup>	100		100		100		10		5		2		5		2	
LEDHR-455 <sup>(1)</sup>	148	270	192	351	222	405	666	1215	681	1242	814	1485	1036	1890	1066	1944
LEDHR-470 <sup>(1)</sup>	131	255	170	332	197	383	590	1148	603	1173	721	1403	917	1785	943	1836
LEDHR-505 <sup>(1)</sup>	90	160	113	200	135	240	297	528	306	544	315	560	432	768	468	832
LEDHR-530 <sup>(1)</sup>	80	145	100	181	120	218	264	479	272	493	280	508	384	696	416	754
LEDHR-595 <sup>(1)</sup>	36	85	45	106	54	128	119	281	122	289	126	298	0	0	252	595
LEDHR-617 <sup>(1)</sup>	246	340	308	425	369	510	935	1292	1230	1700	1427	1972	0	0	1722	2380
LEDHR-630 <sup>(1)</sup>	177	280	230	364	266	420	673	1064	885	1400	1027	1624	0	0	1239	1960
LEDHR-3500 <sup>(1)</sup>	70	120	88	150	105	180	315	540	322	552	385	660	490	840	504	864
LEDHR-5500 <sup>(1)</sup>	115	190	144	238	173	285	518	855	529	874	633	1045	805	1330	828	1368
LEDH-455 <sup>(2)</sup>	211	272	274	354	317	408	950	1224	971	1251	1161	1496	1477	1904	1857	2394
LEDH-470 <sup>(2)</sup>	201	320	261	416	302	480	905	1440	925	1472	1106	1760	1407	2240	1769	2816
LEDH-505 <sup>(2)</sup>	167	210	209	263	251	315	551	693	568	714	585	735	802	1008	868	1092
LEDH-530 <sup>(2)</sup>	92	170	115	213	138	255	304	561	313	578	322	595	442	816	478	884
LEDH-595 <sup>(2)</sup>	99	150	124	188	149	225	327	495	337	510	347	525	0	0	693	1050
LEDH-617 <sup>(2)</sup>	235	350	294	438	353	525	893	1330	1175	1750	1363	2030	0	0	1645	2450
LEDH-630 <sup>(2)</sup>	262	380	341	494	393	570	996	1444	1310	1900	1520	2204	0	0	1834	2660
LEDH-3500 <sup>(2)</sup>	108	180	135	225	162	270	486	810	497	828	594	990	756	1260	950	1584
LEDH-5500 <sup>(2)</sup>	158	240	198	300	237	360	711	1080	727	1104	869	1320	1106	1680	1390	2112

Table 1. Optical power range of various models of LED heads vs. HPLS-36 model, current, and duty cycle.

- (1) Note: Optical power for LEDHR is measured after reflector, using 2" (5cm) diameter optical power meter placed on optical axes 4" (10 cm) from the LED
- (2) Note: For LEDH, the optical power is total of the chip before any optics, and measured by 2" (5cm) diameter optical power meter placed on optical axes touching the LED lens.
- (3) Due to the nature of the semiconductor structures involved, important parameter of LEDs such as optical power, maximum current that LED can tolerate, spectrum and voltage drop, vary greatly for different batches and affect the performance of the HPLS-36 series light sources. It is not uncommon that the power of LEDs from different batches differs 2 times and more. The information presented here should be used for reference only. Please ask if your application demands more stringent requirements.
- (4) Optical power is measured with LED head attached to the HPLS-36 unit, at the room temperature 25C.
- (5) Optical power indicated is power range while ON, for Digital models, and maximum power for continuously variable models. Please note the 2-channel models such as AD3500 and AD3500-DI, presented in 2 columns, for digital and analog channels, respectively.
- (6) Duty cycle affects the performance of LEDs. Typically, for a given current, optical power is higher for lower duty cycle due to lower heating effect of the LED chip. For the pulsed units, exceeding duty cycles indicated for the given current can cause permanent damage to the LED. Some HPLS-36 models have built-in protection against exceeding duty cycle, however, due to wide spread of duty cycle requirements and flexible nature of HPLS-36 series, it is impossible to satisfy to all the requirements in one unit.

# LED Heads

## LEDH, LEDHR series



### Specifications p.2

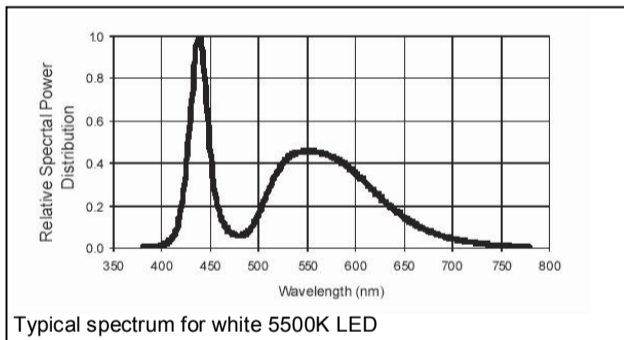
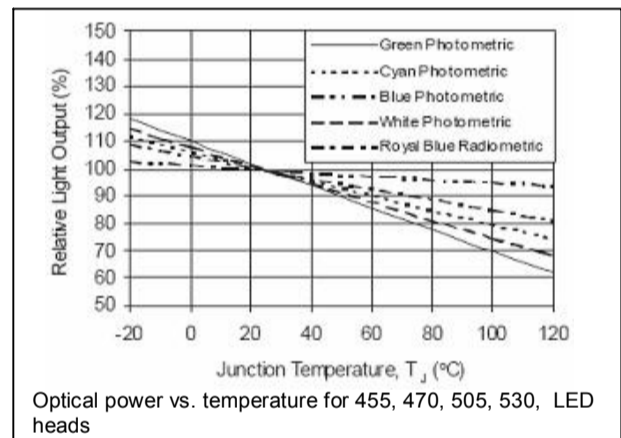
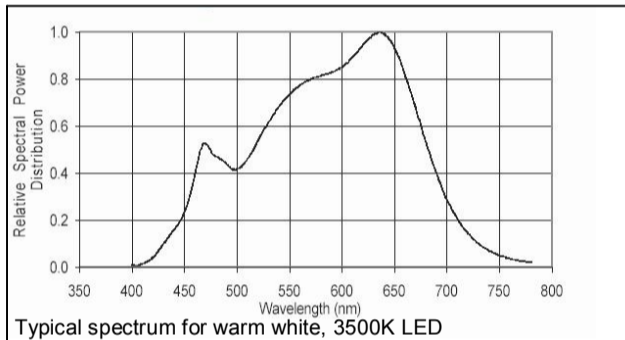
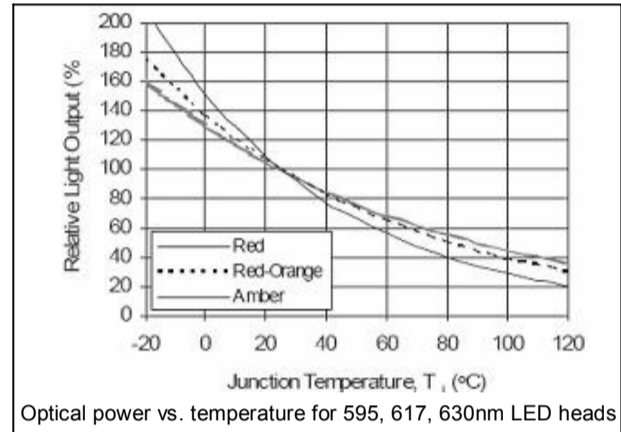
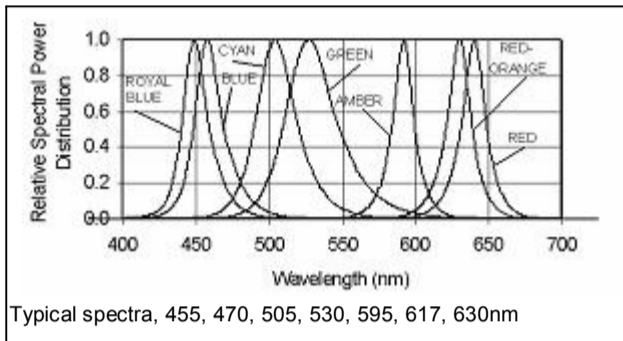

#### Ordering information:

- LEDH[R] - XXXX (color, temperature) – XXXX (performance model, for LEDH only)
- 455 (royal blue)
  - 470 (blue)
  - 505 (cyan)
  - 530 (green)
  - 590 (amber)
  - 617 (red orange)
  - 630 (red)
  - 3500 (warm white)
  - 5500 (bright white)
- omitted: 1.0x1.0 mm die, basic performance
  - 3: 1.0x1.0mm die, high brightness, high power
  - 5: 3x3mm die, moderate brightness, high power
  - K2: 1.0x1.0mm die, best brightness, best power

#### examples:

- LEDHR-470: blue, 1.2" pitch, with reflector, basic performance LED head
- LEDH-530: green, 0.8" pitch, basic performance LED head.
- LEDH-455-K2: royal blue, 0.8" pitch, best brightness/power LED head.

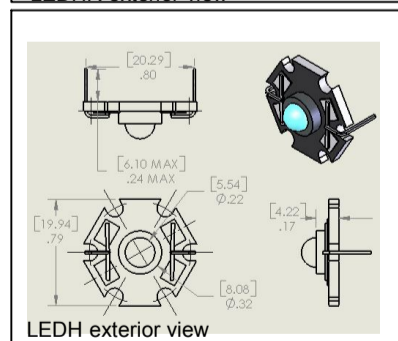
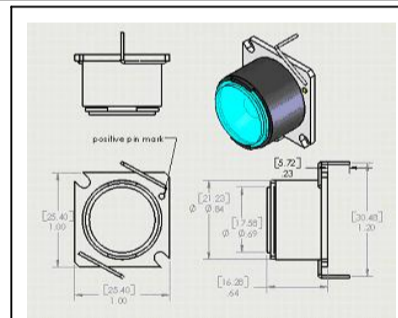

# Terms and Conditions



---

## Prices and Quotations

All quotations are valid for 30 days unless stated otherwise. Published prices are subject to change without notice. Custom and specialty products are individually priced per requirements specified and subject to change if changes are made from original request.

## Purchase Orders and Payment Methods

Orders are accepted by email, mail, and fax. Verbal orders are not advised but accepted on individual basis. Payments by Net 30 account upon approval of credit or by credit card. Late fee 2% per month invoiced if past due. International customers: 100% pre-payment, credit card, or wire transfer Net 30 with approved credit.

## Delivery and shipping.

Shipments are made domestically by USPS priority or FedEx prepaid and added to invoices unless shipping method and shipping account number provided with order. International shipments do not include importation or duty fees and international shipping charges are specified with product quotes.

## Safety warnings and operating conditions.

Lightspeed Technologies is not liable for equipment damage or personal injury resulting from the use of these products. Do not look into the beam directly, or stare at the specular reflection from reflective surfaces such as mirrors. Do not operate unless LED head is secured by 2 screws. Do not disassemble drivers unless to access user-level controls inside per user manual. Do not operate outdoors, in high humidity or condensing environment. HPLS series of light sources and drivers are designed for operation in indoor environment, non-condensing conditions, with ambient temperature from 4.5°C to 29.5°C (40°F to 85°F).

## Warranty Terms and Conditions

Lightspeed Technology's products, HPLS base units, drivers, optics, accessories (except LED heads) are warranted to be free from manufacturing defects in materials, parts and labor for a period of 1 year from the date of delivery to a customer, customer's shipping department, and/or designated agent. Components that are subject for failure per conditions specific to customer's testing environment, including but not limited to, incompatible line outlet voltage, out-of-the-specifications line outlet voltage, incompatible signal voltages and/or timing requirements; specifically including, but not limited to, LED heads, are warranted for a period of 90 days.

## Returns and cancellation conditions.

No returns on special order items, or if a demo unit was requested, furnished and subsequently tested by a customer prior to placing an order. All products should be returned with original packaging material. All returns are subject to inspection and restocking fees upon arrival if without original packaging, damaged, or otherwise tampered with. Contact Lightspeed Technologies for a return materials authorization (RMA) number and shipping address if product is to be returned. No returns after 30 days from the day of product delivery to a customer, shipping department, or designated agent. Lightspeed Technologies will make the determination of cause of damage and if warranty replacement is applied.

Lightspeed Technologies  
P.O. Box 110161  
Campbell, CA 95011-0161  
(408)761-0062  
sales@light-speed-tech.com